

**SOLUTION FOCUSED
SERVICE DRIVEN**

LIQUIP VICTORIA
THE HOME OF Fuelcraft



HOST Fire Rated Self Bunded Tanks

Store fuels and flammable bulk liquids more safely.

The Liquip Fireguard® Tank design incorporates lightweight thermal insulation encased between two walls of steel. The double wall steel design provides secondary containment. The lightweight interstitial insulation material is 75% lighter than concrete reducing the overall tank weight significantly when compared to competing concrete encased products.

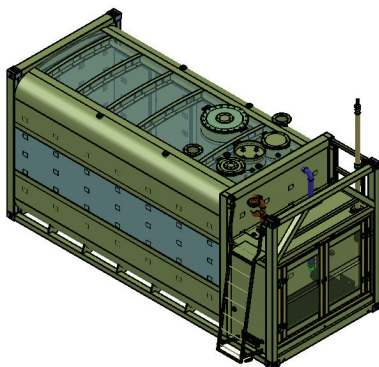

This tank is UL 2085 labelled as a 'fire-protected and 'fire-resistant' secondary containment above ground tank with a 2-hour fire-rating. Also available in 4-hour 240/240/240 fire-rating.



*Liquip Victoria
Fire Rated
Fireguard Tanks
can be supplied
in square or
round style tank
designs and
with dispensing
systems installed.*

**Liquip Victoria's HOST Fireguard®
Self Bunded Storage Tank features
& key benefits**

- Insulates product in tank from ambient temperature variations, reducing emissions to the environment.
- Primary and secondary tank can be tightness tested on site with standard testing procedures.
- Steel outer wall provides low cost maintenance and protection from weathering.
- Primary storage tank and secondary containment compatible with a wide range of fuels and chemicals, including biodiesel, ethanol, Avgas and Jet A-1.
- Support designs available for all seismic requirements.
- Interstitial space can be monitored for leak detection.
- Separation distances to on-site and off-site protected places, boundaries and security fences are reduced and maybe halved as per AS1940-2017
- Petrol and diesel dispensers/pumps that are suitably approved for use in hazardous areas around the tank, may be mounted on the tank as per AS1940-2017 and AS2229
- Also available in 4-hour 240/240/240 fire-rating.

GENERAL BUILD SPECIFICATIONS

- Paint Finish: 3 coats of Hempel paint 240 micron to corrosivity category C4.
- Fitted with primary and secondary UL certified emergency vents.
- Calibrated dipsticks for primary tank and interstitial space.
- Anti-syphon valve and mechanical overflow protection valve standard.
- Audible/visual alarms and hazardous rated versions.
- Multiple ports on top of the tank for instrumentation, sub pumps, ATG or tank gauges.

TANK SIZES:

- 2,000 litre to 100,000 litre.
- Single or Multi-compartment Design.
- Manufactured in any shape to suit the site.

CERTIFICATIONS

- AS1692-2006 Steel tanks for Flammable & Combustible Liquids.
- AS1940-2004 The storage and handling of Flammable & Combustible Liquids.
- Ballistics and Impact protection per UL 2085.
- Steel Tank Institute (STI) Standard F941 for Thermally Insulated Above ground Storage Tanks.
- UL 142 & UL 2085 Standards.

ADDITIONAL SUPPLY OPTIONS

- Stainless Steel construction.
- Lockable Pump Bay.
- Avgas and Jet A-1 suitability.
- Multiple compartment construction, to support more than one bulk liquid storage option in the one tank.

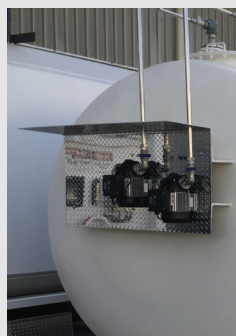

Pump Dispensing Systems



Square tank top – fill points & vents



Square Fire Rated Tank – with all inclusive custom pump dispensing system

Standard Sizes (special sizes also available)

2-hour Fire Rated Tanks – Self Bunded Tank series sizes and models available from Liquip Victoria

Tank Model	Gross Capacity (Litres)	Safe Fill Capacity (Litres)	A. Tank Length (metres)	B. Tank Width (metres)	C. Tank Height (metres)	Dispensing options	ISO Container
LV-FRT10-2	10,000	9,500	2.993	2.438	2.896	Pump Bay	10-foot
LV-FRT15-2	15,000	14,250	2.993	2.438	2.896	No Pump Bay	10-foot
LV-FRT28-2	28,000	26,600	6.058	2.438	2.896	Pump Bay	20-foot
LV-FRT33-2	33,000	31,350	6.058	2.438	2.896	No Pump Bay	20-foot
LV-FRT56-2	56,000	53,200	12.192	2.438	2.896	Pump Bay	40-foot
LV-FRT61-2	61,000	57,950	12.192	2.438	2.896	No Pump Bay	40-foot
LV-FRT63-2	63,000	59,850	12.192	2.438	3.200	Pump Bay	40-foot HC
LV-FRT69-2	69,000	65,550	12.192	2.438	3.200	No Pump Bay	40-foot HC
LV-FRT77-2	77,000	73,150	14.630	2.438	3.200	Pump Bay	48-foot HC
LV-FRT83-2	83,000	78,850	14.630	2.438	3.200	No Pump Bay	48-foot HC

4-hour Fire Rated Tanks – Self Bunded Tank series sizes and models available from Liquip Victoria

Tank Model	Gross Capacity (Litres)	Safe Fill Capacity (Litres)	A. Tank Length (metres)	B. Tank Width (metres)	C. Tank Height (metres)	Dispensing options	ISO Container
LV-FRT8B-4	8,000	7,600	2.993	2.438	2.896	Pump Bay	10-foot
LV-FRT13B-4	13,000	12,350	2.993	2.438	2.896	No Pump Bay	10-foot
LV-FRT23B-4	23,000	21,850	6.058	2.438	2.896	Pump Bay	20-foot
LV-FRT28B-4	28,000	26,600	6.058	2.438	2.896	No Pump Bay	20-foot
LV-FRT48B-4	48,000	45,600	12.192	2.438	2.896	Pump Bay	40-foot
LV-FRT52B-4	52,000	49,400	12.192	2.438	2.896	No Pump Bay	40-foot
LV-FRT55B-4	55,000	52,250	12.192	2.438	3.200	Pump Bay	40-foot HC
LV-FRT60B-4	60,000	57,000	12.192	2.438	3.200	No Pump Bay	40-foot HC
LV-FRT67B-4	67,000	63,650	14.630	2.438	3.200	Pump Bay	48-foot HC
LV-FRT72B-4	72,000	68,400	14.630	2.438	3.200	No Pump Bay	48-foot HC

476 Boundary Rd
Derrimut
VICTORIA 3026

Phone: 03 9311 7822
E-mail: sales@liquipvictoria.com.au

